

DEPARTMENT OF THE ARMY TECHNICAL MANUAL

INSTRUCTIONS FOR INSTALLING INSTALLATION KIT,
ELECTRONIC EQUIPMENT MK-1239/VRC-12 IN TRUCK,
CARGO, 1 1/4 TON, M715 (RADIO SET AN/VRC-12)

Headquarters, Department of the Army, Washington, D.C.
26 November 1973

		Paragraph	Page
CHAPTER	1.	INTRODUCTION	
		Scope	1-1 2
		Destruction of Army material to prevent enemy use.....	1-2 2
		Maintenance forms and records.....	1-3 2
		Reporting of equipment publication improvements.....	1-4 2
	2.	INSTALLATION	
Section	I.	Service upon receipt of MK-1239/VRC-12	
		Unpacking and checking MK-1239/VRC-12 items	2-1 3
		Items comprising Installation Kit, Electronic Equipment MK-1239/VRC-12...	2-2 3
	II.	Installation of MK-1239/VRC-12	
		Tools required for installation	2-3 5
		Installation instructions.....	2-4 5
APPENDIX	A.	REFERENCES	6

CHAPTER 1

INTRODUCTION

1-1. Scope

This manual provides instructions for the installation of Installation Kit, Electronic Equipment MK-1239/VRC-12 FSN 5820-469-6683, in Truck, Cargo, 1-1/4 Ton, M715. This installation kit permits mounting of Radio Set AN/VRC-12.

NOTE

Refer to SB 11-131 for a complete listing of vehicular radio sets and authorized installations.

1-2. Destruction of Army Material to Prevent Enemy Use

Refer to TM 740-244-2 for instructions in the destruction of equipment to prevent enemy use.

1-3. Maintenance Forms and Records

Department of the Army forms and records used for equipment maintenance will be those prescribed by TM 38-750.

1-4. Reporting of Equipment Publication Improvements

The reporting of errors, omissions, and recommendations for improving this publication by the individual user is encouraged. Reports should be submitted on DA Form 2028 (Recommended Changes to Publications) and forwarded direct to Commander, US Army Electronics Command, ATTN: AMSEL-MA-CR, Fort Monmouth, NJ 07703.

CHAPTER 2
INSTALLATION

Section I. SERVICE UPON RECEIPT OF MK-1239/VRC-12

2-1. Unpacking and Checking MK-1239/VRC-12 Items

a. Move the packing boxes close to the location where the installation is to take place and unpack the parts of the MK-1239/VRC-12. Be careful not to lose any of the parts.

b. Inspect the items for damage incurred during shipment. If any of the items have been damaged, report the damage on DD Form 6 (Report of Packaging and Handling Deficiencies) as prescribed in AR 700-58

c. Check the equipment against the listing in paragraph 2-2 and the packing slip to see if the shipment is complete. The equipment should be placed in service even though a minor assembly or part that does not affect proper installation is missing.

d. When wheeled vehicles with radio sets are to be turned in or transferred, the radio sets and the installation kit will be removed and reinstalled in the new replacement vehicle. Refer to SB 11-131 if the radio set is to be installed in another type of vehicle. It should be noted that both the basic radio set and the MK-1239/VRC-12 are separate accountable items and are not considered part of the vehicle.

2-2. Items Comprising Installation Kit, Electronic Equipment MK-1239/VRC-12

The items which comprise MK-1239/VRC-12 are listed in table 2-1. A Federal stock number (FSN) has been provided for each item. Tables 2-2 through 2-6 list the items in the mountings, clamp strap, sheet metal screw clamp, and audio accessory support kits.

Table 2-1. Items Comprising Installation Kit, Electronic Equipment MK-1239/VRC-12

FSN	Item	Quantity	Length	Remarks
5820-892-3340	Control, Radio Set C-2299/VRC.....	1		MIL-C-55126
5820-892-3343	Control, Frequency Selector C-2742/VRC.....	1		MIL-C-55126
5820-763-2462	Bracket Assembly.....	1		SC-C-189025
5820-254-4340	Base, Antenna AB-243/G.....	1		SC-C-28642
5820-740-1780	Support Assembly.....	1		SC-D-189023
5820-937-7212	Reinforcement.....	2		SC-B-425939
5820-763-2463	Reinforcement.....	1		SC-B-189026
5820-937-7227	Bracket.....	1		SC-D-425918
5995-173-7116	Bond Strap (GP III).....	2		SC-B-75180
5995-823-2987	Cable Assembly, Radio Frequency CG-1773B/U.....	1	4 ft	SM-D-415563
5995-823-2990	Cable Assembly, Radio Frequency CG-1773B/U.....	1	8 ft	SM-C-415563
5995-823-2820	Cable Assembly, Special Purpose, Electrical CX-4722/VRC.....	1	7 ft	SM-D-415552
5995-823-2839	Cable Assembly, Special Purpose, Electrical CX-7059/VRC.....	1	13 ft	SM-D-415559
5995-823-2841	Cable Assembly, Special Purpose, Electrical CX-4723/VRC.....	1	15 ft	SM-D-415553
5995-935-0383	Cable Assembly, Special Purpose, Electrical CX-7867A/VRC.....	1	13 ft	SC-D-436058
5820-752-5738	Clamp Strap Kit (table 2-2).....	3		
6150-637-8054	Grommet, Rubber.....	2		MS-35489-53
5325-826-4020	Grommet, Rubber.....	1		MS-35489-120
5965-892-1010	Headset Electrical, H-140B/U.....	1		MIL-E-55119
5965-875-1313	Microphone, Dynamic, M-80C/U.....	1		MIL-E-55119
5970-313-8951	Insulator IL-2/U.....	1		SC-D-8469
5965-876-2375	Loudspeaker, Permanent Magnet LS-454/U.....	2		MIL-L-12632
	Grommet, Rubber.....	2		MS-35490-87
5820-875-0940	Mounting Bracket Assembly.....	1		SC-C-425873
5820-875-0936	Mounting Bracket Assembly.....	1		SC-C-425876
5820-078-3895	Sheet Metal Screw Clamp Kit (table 2-3).....	2		

Table 2-1. Items Comprising Installation Kit, Electronic Equipment MK-1239/VRC-12-Continued

FSN	Item	Quantity	Length	Remarks
5935-666-1649	Adapter, Connector UG-306B/U	1		MS-35368
5820-064-5042	Bracket Assembly	1		SC-D-19763
5820-856-9165	Audio Accessory Support Kit (table 2-4)	1		
5820-937-1082	Seat Bracket Assembly	1		SC-D446095
5820-937-7218	Support Assembly	1		SC-D446096
5820-937-7213	Brush Guard Assembly	1		SC-D-446094
5305-068-0504	Screw, Hex, Hd, 5/16-24 x 3/4 lg	4		MS-90726-3
5310-269-6538	Lockwasher, 5/16 ET	4		MS45904-72
5310-582-5615	Nut, Hex, 5/16-24.....	4		MS-35690-522
5305-068-0506	Screw, Hex Hd, 1/4-28 x 3/4 lg	4		MS-90726-6
5310-637-9575	Lockwasher, 1/e IET	4		MS-45904-68
5310-543-4568	Nut, Hex, 1/4-28.....	4		MS-35690-422
5340-916-6539	Loop, Strap Fastener	1		MS-51939-2
5310-012-0614	Nut, Plain, Tex, #10-32	2		MS-35650-102
5305-989-7434	Screw, Pan Hd. 10-32 x 1/2 lg.....	2		MS-35207-263
5310-809-8546	Washer, Flat, #10	2		MS-27183-8
5820-437-2353	Antenna Tip Assembly (for AT-1095/VRC)	1		SC-C-446180
5985-930-7223	Antenna Tip Assembly (for MS-118A)	1		SC-C-446046
5935-149-3534	Adapter UG-273/U	1		MIL-C-3608 (RD49F389)
5820-497-9644	Bag CW-206/GR.....	1		MIL-B-12325 (SC-DL-23003)
5995-823-2726	Cable Assembly, Power, Electrical CX-4720-/VRC.....	1	10 ft.	SM-D-415550
5995-823-2725	Cable Assembly, Power, Electrical CX-4721/VRC.....	1	2.5 ft.	SM-D-415551
5985-221-5544	Mast Base AB-15/GR.....	1		MIL-M-12320 SC-DL-100581
5820-199-8831	Mast Section MS-116A	1		MIL-M-12320 SC-DL-100588
5820-199-8843	Mast Section MS-117A	1		MIL-M-12320 SC-DL-100588
5820-199-8841	Mast Section MS-118A	1		MIL-M-12320 SC-DL-100588
5820-893-1323	Mounting MT-1029/VRC (table 2-5).....	1		
5820-893-1324	Mounting MT-1898/VRC (table 2-6).....	1		
5820-937-7219	Strip Assembly.....	2		SC-D-446112

Table 2-2. Clamp, Strap Kit (FSN 5820-752-5738)

Item	Quantity	Remarks
Clamp, strap	3 ft	SC-B-35513
Nut, Plain, hexagon; carbon steel, cad pl; 1/4-28 UNF-2B; 7/32 nom thk.....	12	MS 35690-422
Washer, lock, flat; heavy; int teeth; .045 max thk; 1/4 nom size	12	MS 35334-19
Clamp strap fastener assembly.-	12	SC-C-279924 (Group I)

NOTE
Dimensions are in inches

Table 2-3. Sheet Metal Screw Clamp Kit (FSN 5820-078-3895)

<i>Item</i>	<i>Quantity</i>	<i>Remarks</i>
Clamp strap	3 ft	SC-B-35513
Clamp strap fastener assembly	12	SC-C-279927 (Group 1)

Table 2-4. Audio Accessories Support Kit (FSN 5820.856-9165)

<i>Item</i>	<i>Quantity</i>	<i>Remarks</i>
Cloth mailing bag 3 1/2" by 5", with draw string and tag attached	1	Commercial
Printing on tag to read as follows: "Audio accessories kit FSN 5820-856-9165. To be installed in the vehicle at discretion of user."		
Hook, steel.....	2	SC-A-5276
Screw pan hd. sheet metal #8 3/4 inch lg.....	5	MS-24637-25
Screw pan hd. machine screw 8-32 x 3/4 inch lg.....	5	MS-35223-47
Washer, lock, ET #8 ---	5	MS-45904-57
Nut, hex 8/32	5	MS-35649-82

NOTE

Cloth mailing bag contains above hardware items.

Table 2-5. Mounting MT-1029()/VRC (FSN 5820.893-1323)

<i>Item</i>	<i>Quantity</i>	<i>Remarks</i>
Cover, dust FSN 5935-933-3752.....	3	SM-B104328
ing Hardware Kit for Mounting MT-1029 () /VRC includes:		SC-B-415045
Bag, cotton, (container for hardware.....	1	SM-B-415047
Screw, cap; hex, cad, pl; 5/16-24 x 1 1/4 inch	5	SM-C-415048-1
Screw, cap; hex, cad, pl; 5/16-24 x 3/4 inch	5	SM-C-415048-3
Washer, lock; flat, 5/16 inch., external tooth. cad, pl, Finish M225 per MIL-F-14072	10	MS-35335-6
Nut, hex; Class 3, Type II, cad, pl, per Spec., QQ-P-416 Finish M225 per MIL-F-14072.....	5	MS-35690-522
Terminal, lug, solder; H- B. Sherman Co. # 316, or equal.....	2	Commercial

Table 2-6. Mounting MT-1898()/VRC (FSN 5820-893-1324)

<i>Item</i>	<i>Quantity</i>	<i>Remarks</i>
Cover, dust FSN 5935-933-3752.....	3	SM-B-104328
Mounting Hardware Kit for Mounting MT-1898()/VRC includes:		SC-B-415087
Cover, electrical connector FSN 5935-911-2323	1	SC-C-555860
Bag, cotton; (container for hardware)	1	DDD-B-20
Screw, cap; hex, cad. pl; 5/16-24 x 1 1/4 inch.....	4	MS-35292-36
Screw, cap; hex, cad. pl; 5/16-24 x 3/4 inch	4	MS-35392-32
Washer, lock; flat, 5/16 inch external tooth.....	8	MS-35335-34
Nut, hex; Class 3, Type II, cad, pl; per Spec., QQ-P-416.....	4	MS-35690-522

Section II. INSTALLATION OF MK-1239/VRC-12

2-3. Tools Required for Installation.

The tools required for installation of MK-1239/VRC-12 are contained in Tool Kit, Electronic Equipment TK-100/G, FSN 5180-605-0079. The following additional items are needed:

- a. One 3/8-inch twist drill FSN 5133-277-9666.
- b. One 3/8-inch portable electric drill FSN 5130-293-3456.
- c. Chassis punches (Greenlee), 1 1/16-inch, and 1 1/4-inch. See Note.

2-4. Installation Instructions

- a. To accomplish the installation follow the instructions shown on figures FO-1 (1), and FO-1 (2).

- b. The following additional information is provided:

(1) To drill the correct size holes for the sheet metal screws which hold the plastic cable clamps, select a drill bit that is slightly smaller in diameter than screw.

(2) When the installation is completed, check the tightness of all bolts and screws.

- c. Refer to technical manuals supplied with Radio Set AN/VRC-12 for operation and maintenance instructions.

NOTE

The FSN's for 1 1/16" and 1 1/4" chassis punches are 5110-180-0915, and 5110-2930103, respectively.

APPENDIX REFERENCES

AR700-58	Report of Packing and Handling Deficiencies.
DA Pam 310-4	Index of Technical Manuals, Technical Bulletins, Supply Manuals (Types 7, 8, and 9), Supply Bulletins, and Lubrication Orders.
DA Pam 310-7	U.S. Army Equipment Index of Modification Work Orders.
SB 11-131	Vehicular Radio Sets and Authorized Installations.
SB 11-573	Printing and Preservation Supplies Available for Field Use for Electronics Command Equipment.
SB 38-100	Preservation, packing, Packing and Marking Materials, Supplies, and Equipment used by the Army.
SC 5180-91-CL-S21	Sets, Kits, and Outfits Component List: Tool Kit, Electronic Equipment TK-100/G
TB 746-10	Field Instructions for Painting and Preserving Electronics Command Equipment.
TB SIG 291	Safety Measures to be Observed when Installing and Using Whip Antennas, Field Type Masts, Towers Antennas, and Metal Poles that are Used with Communication, Radar and Direction Finder Equipment
TM 11-5820-401-12	Operator's and Organizational Maintenance Manual Including Repair Parts and Special Tool Lists: Radio Sets AN/VRC-12, and AN/VRC-43, 44, -45, -46, -47, -48, and -49.
TM 11-5820-401-35	DS, GS, and Depot Maintenance Manual Including Repair Parts and Special Tool Lists: Radio Sets AN/VRC-12 and AN/VRC-43, -44, -45, -46, -47, -48, and -49.
TM 38-750	The Army Maintenance Management System (TAMMS).
TM 750-244-2	Procedures for Destruction of Electronics Material to Prevent Enemy Use (Electronics Command).

By Order of the Secretary of the Army:

CREIGHTON W. ABRAMS
General, United States Army
Chief of Staff

Official:

VERNE L. BOWERS
Major General, United States Army
The Adjutant General

Distribution:

To be distributed in accordance with DA Form 12-51, (qty rqr block No. 599) Direct and General Support maintenance requirements for AN/VRC-12.

☆ U.S. GOVERNMENT PRINTING Office:1991 - 281-486/42438

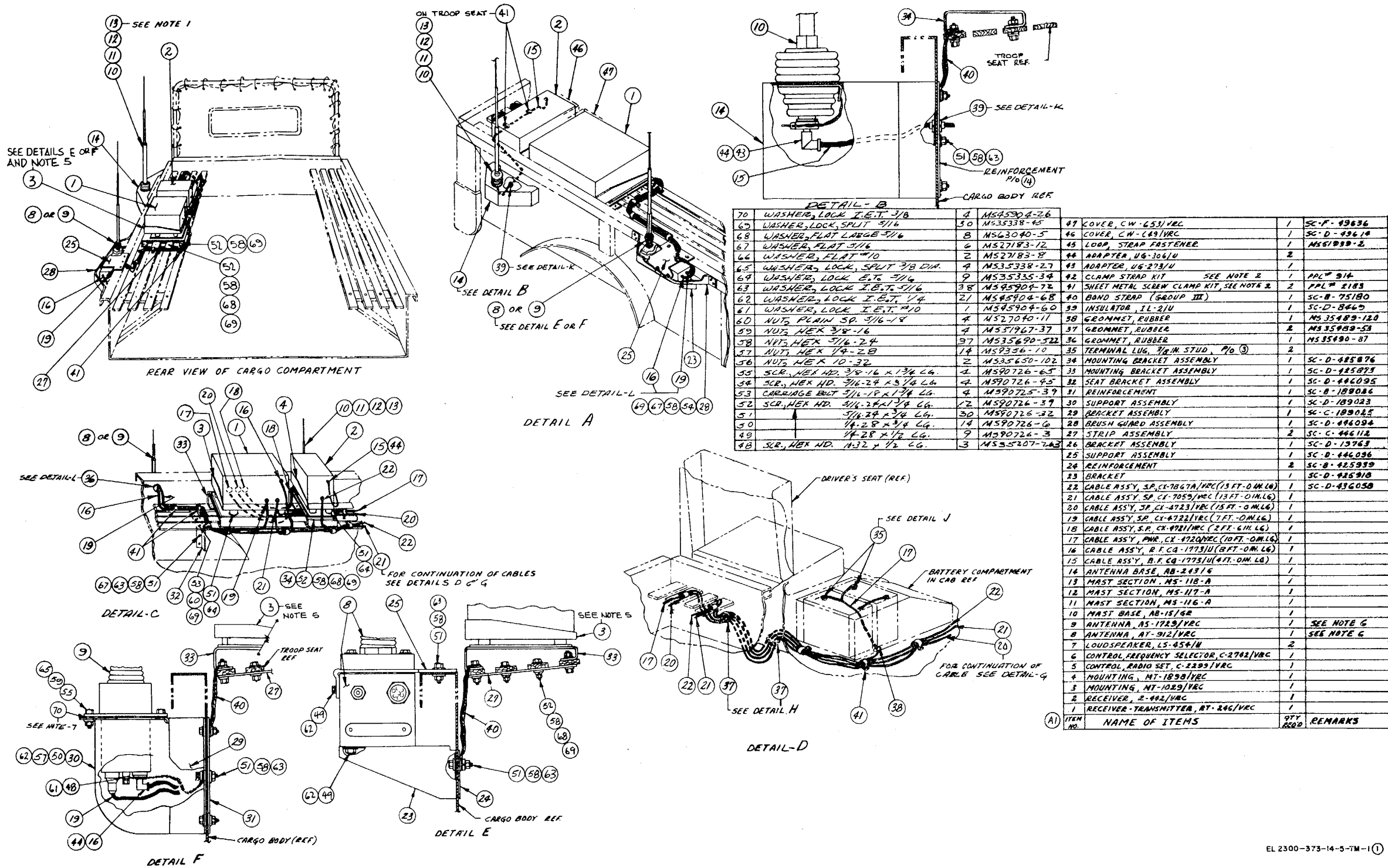

Figure FO-1 (1). Installation of Radio Set AN/VRC-12 in truck, cargo, 1 1/4 ton, 4x4, M715.

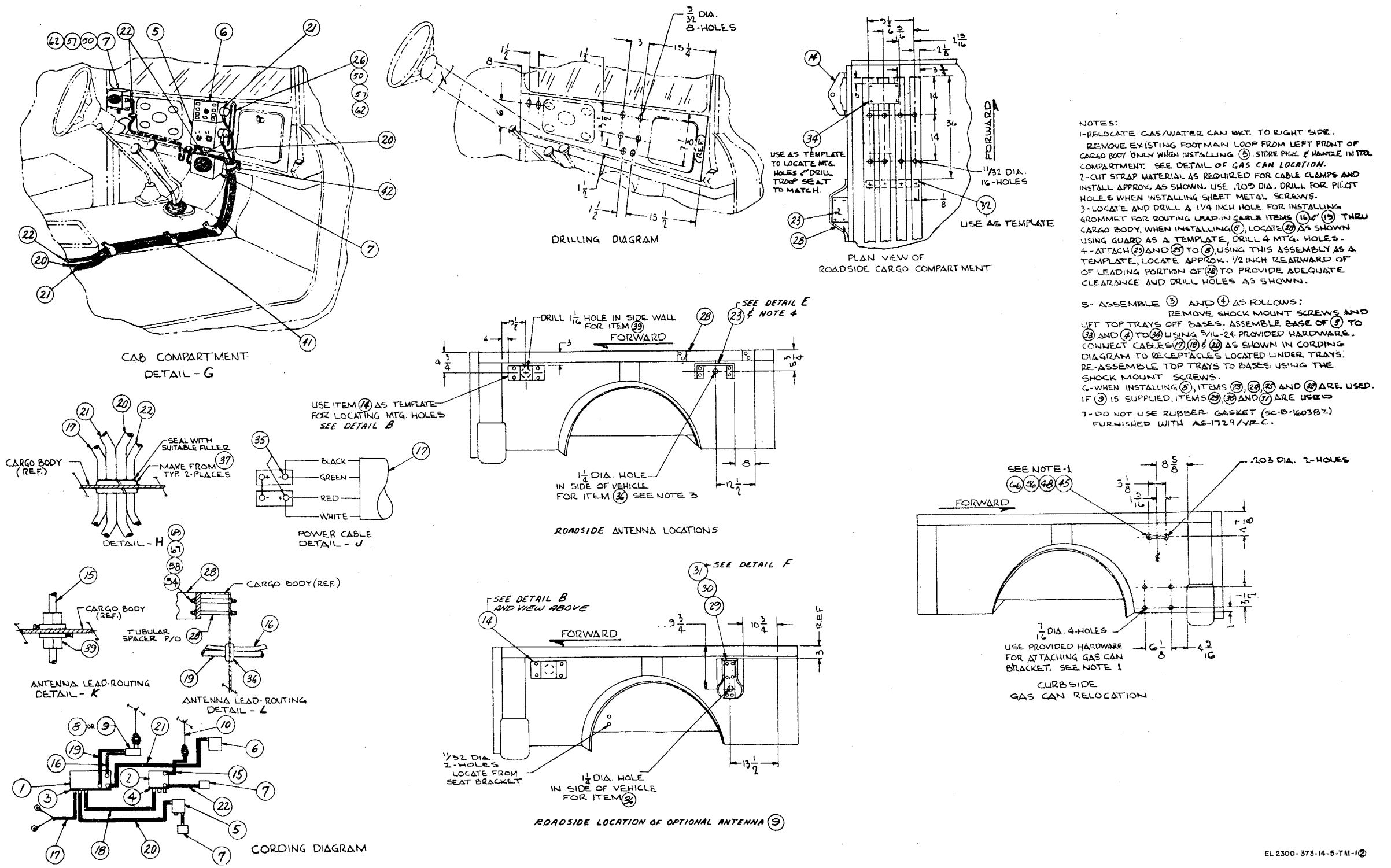

Figure FO-1 (2). Installation of Radio Set AN/VRC.12 in truck, cargo, 1 1/4 ton, 4x4, M715.

RECOMMENDED CHANGES TO EQUIPMENT TECHNICAL PUBLICATIONS



THEN... JOT DOWN THE DOPE ABOUT IT ON THIS FORM, CAREFULLY TEAR IT OUT, FOLD IT AND DROP IT IN THE MAIL!

SOMETHING WRONG WITH THIS PUBLICATION?

FROM: (PRINT YOUR UNIT'S COMPLETE ADDRESS)

DATE SENT

PUBLICATION NUMBER

PUBLICATION DATE

PUBLICATION TITLE

BE EXACT... PIN-POINT WHERE IT IS

PAGE NO.	PARA-GRAPH	FIGURE NO.	TABLE NO.
----------	------------	------------	-----------

IN THIS SPACE TELL WHAT IS WRONG AND WHAT SHOULD BE DONE ABOUT IT:

TEAR ALONG PERFORATED LINE

PRINTED NAME, GRADE OR TITLE, AND TELEPHONE NUMBER

SIGN HERE:

DA FORM 2028-2 JUL 79

PREVIOUS EDITIONS ARE OBSOLETE.

P.S.—IF YOUR OUTFIT WANTS TO KNOW ABOUT YOUR RECOMMENDATION MAKE A CARBON COPY OF THIS AND GIVE IT TO YOUR HEADQUARTERS.

PIN: 016057-000